

MULTIPRESS® HYDRAULIC PRESSES—SERIES FM

20, 30, 40, 50, 75, 100, 150 and 200 Ton Capacities



Standard Features

- Two Models offered:
FMS with Single Pump
FMD with Double Pump
(faster ram speeds, lower horsepower)
- Adjustable pressure from 20% to 100%
- Adjustable stroke
- Standard NFPA cylinder
- Pump mounted out of the oil for ease of service
- Manifold mounted valves
- Speed change limit switch
- Programmable Logic Controller
- Open Motor
- NEMA-12 control cabinet
- IEC fused disconnect
- 230/460 volts, 3 phase, 60 Hz
- Dual pushbuttons (No-tie-down)
- Electric jog control for setup
- Pressure reversal of ram
- Multipress blue paint
- Adheres to OSHA (ANSI B11.2) Federal Safety Laws

Optional Features and Accessories

- Flange mounted fused disconnect
- Limit switch reversal
- Quality control limit switch
- TEFC motor
- Ergonomic palm buttons
- Counter
- Larger PLC
- Adjustable dwell cycle
- Adjustable pressing speed control
- Programmable stroke control
- Additional daylight
- Additional stroke
- Additional throat
- Filters
- Index tables
- 2 and 4 post tool plates
- Light curtains
- Side guards
- Oil coolers (air or water)
- Special paint

FMS & FMD MODELS	FM-20	FM-30	FM-40	FM-50	FM-75	FM-100	FM-150	FM-200			
Maximum Tonnage	20	30	40	50	75	100	150	200			
FMS Ram Speeds (IPM, ±10%):											
Advance	740	515	495	320	260	220	190	120			
Press	290	250	220	160	125	110	85	60			
Return	475	495	395	330	235	210	150	125			
Horsepower, 1800 RPM	20	25	30	30	40	40	50	50			
FMD Ram Speeds (IPM, ±10%):						A	B	A	B	A	B
Advance	940	750	810	715	630	545	390	515	295	365	190
Press	90	60	100	60	45	45	30	45	20	40	15
Return	605	720	645	745	560	525	370	410	240	380	200
Horsepower, 1800 RPM	10	10	20	20	20	30	20	40	20	50	20
Reservoir Capacity (Gal)	85	85	90	90	150	150	200	200			
Shipping Weight (Approx.)	3,800	4,200	8,500	8,700	9,400	12,100	17,150	19,500			

FMS - Single Pump • FMD - Double Pump
Column A - Standard Speeds • Column B - Lower Speeds/Lower Cost Option

SERIES FM PRESS DIMENSIONS

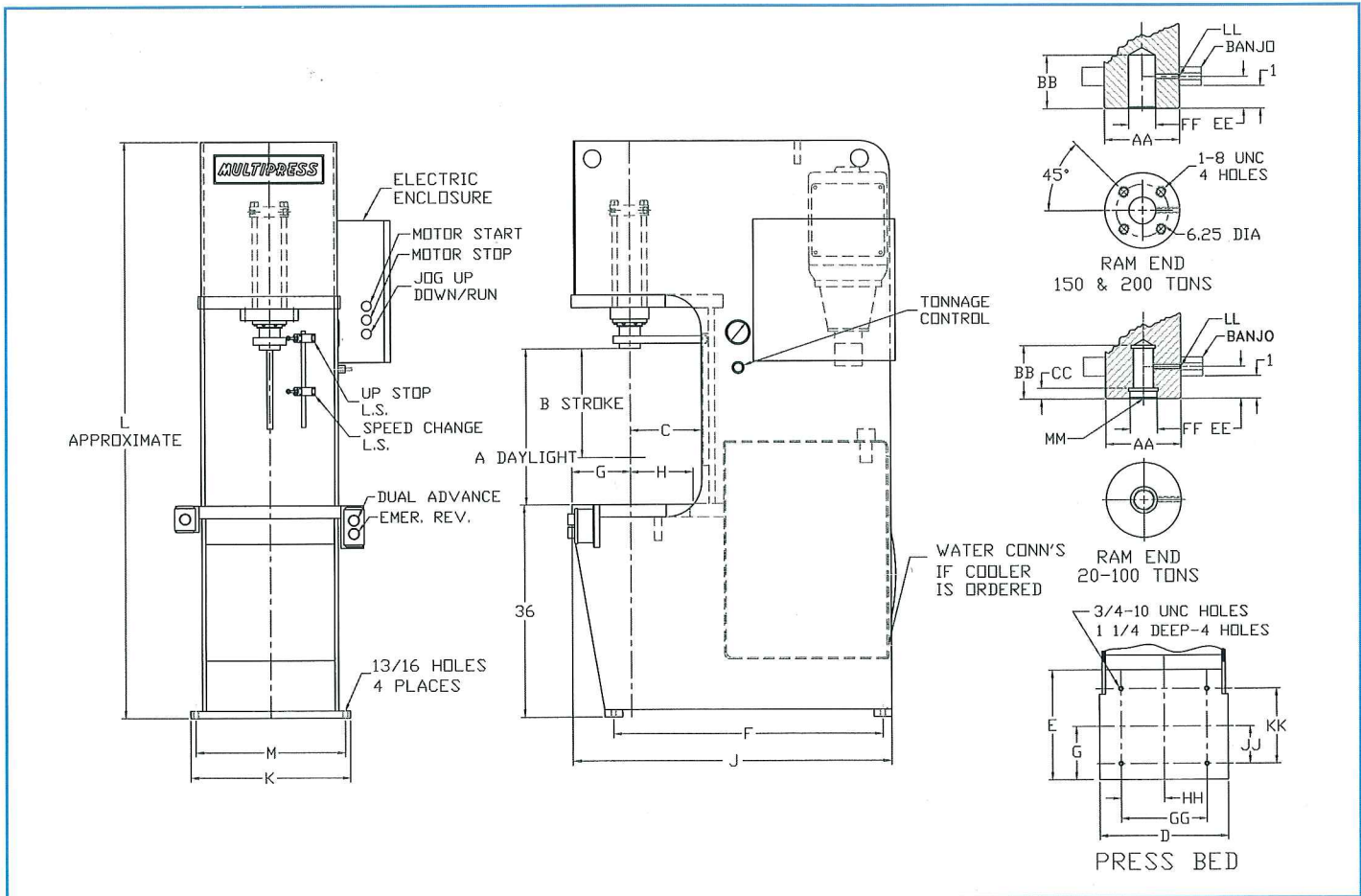

Model	A	B	C	D	E	F	G	H	J	K	L	M
FM-20	20	12	12	24	21	40	10	11	54	27	91	25
FM-30	20	12	12	24	21	40	10	11	54	27	91	25
FM-40	20	12	12	26	21	40	10	11	54	29	92	27
FM-50	20	12	12	26	21	40	10	11	54	29	92	27
FM-75	30	18	14	34	25	44	12	13	66	38	105	36
FM-100	30	18	14	34	25	44	12	13	66	38	105	36
FM-150	36	18	16	36	27	59	12	15	75	40	115	38
FM-200	36	18	16	36	27	59	12	15	75	40	115	38

Model	AA*	BB	CC	EE	FF	GG	HH	JJ	KK	LL	MM
FM-20	2.5	2.5	.50	1.5	1.250/1.252	16	8	7	14	3/8-16 UNC	1-14 UNF
FM-30	3.5	2.5	.50	1.5	1.250/1.252	16	8	7	14	3/8-16 UNC	1-14 UNF
FM-40	4	2.5	.50	1.5	1.750/1.752	16	8	7	14	3/8-16 UNC	1 1/2 - 12 UNF
FM-50	5	3.0	.62	1.5	2.250/2.254	16	8	7	14	3/8-16 UNC	2 - 8 UNF
FM-75	5.5	4.25	.62	1.5	3.000/3.004	22	11	7	14	1/2-13 UNC	2 1/2 - 12 UNF
FM-100	7	6.00	.62	1.62	3.750/3.754	22	11	10	20	1/2-13 UNC	3 1/2 - 12 UNF
FM-150	8	2.0	-	1.62	1.000/1.003	24	12	10	20	1/2-13 UNC	See detail above
FM-200	10	2.0	-	1.62	1.000/1.003	24	12	10	20	1/2-13 UNC	See detail above

* + .001, - .003

MULTIPRESS®

MULTIPRESS, INC
 2222 S. Third Street • Columbus, Ohio 43207
 Telephone (614) 228-0185 • Fax (614) 228-2358
 www.multipress.com